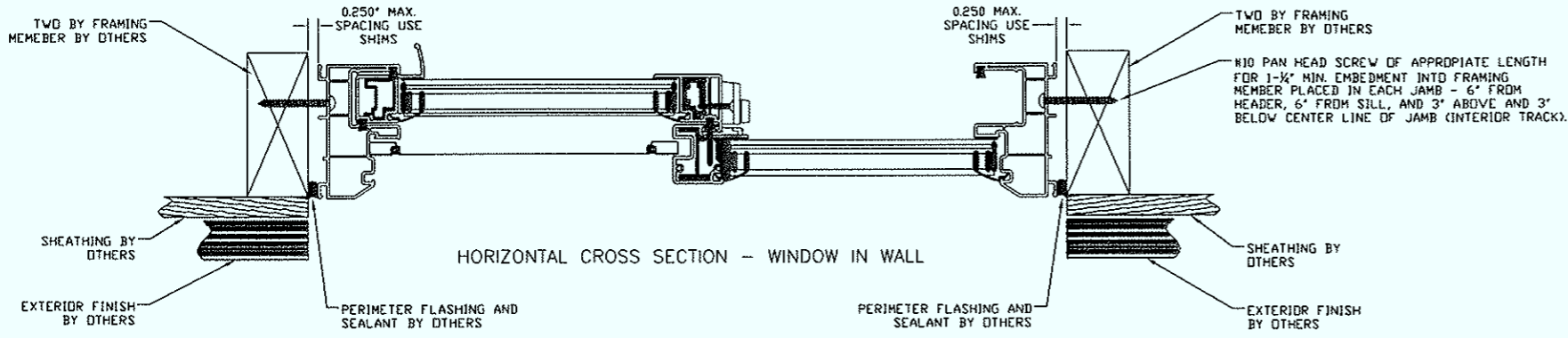
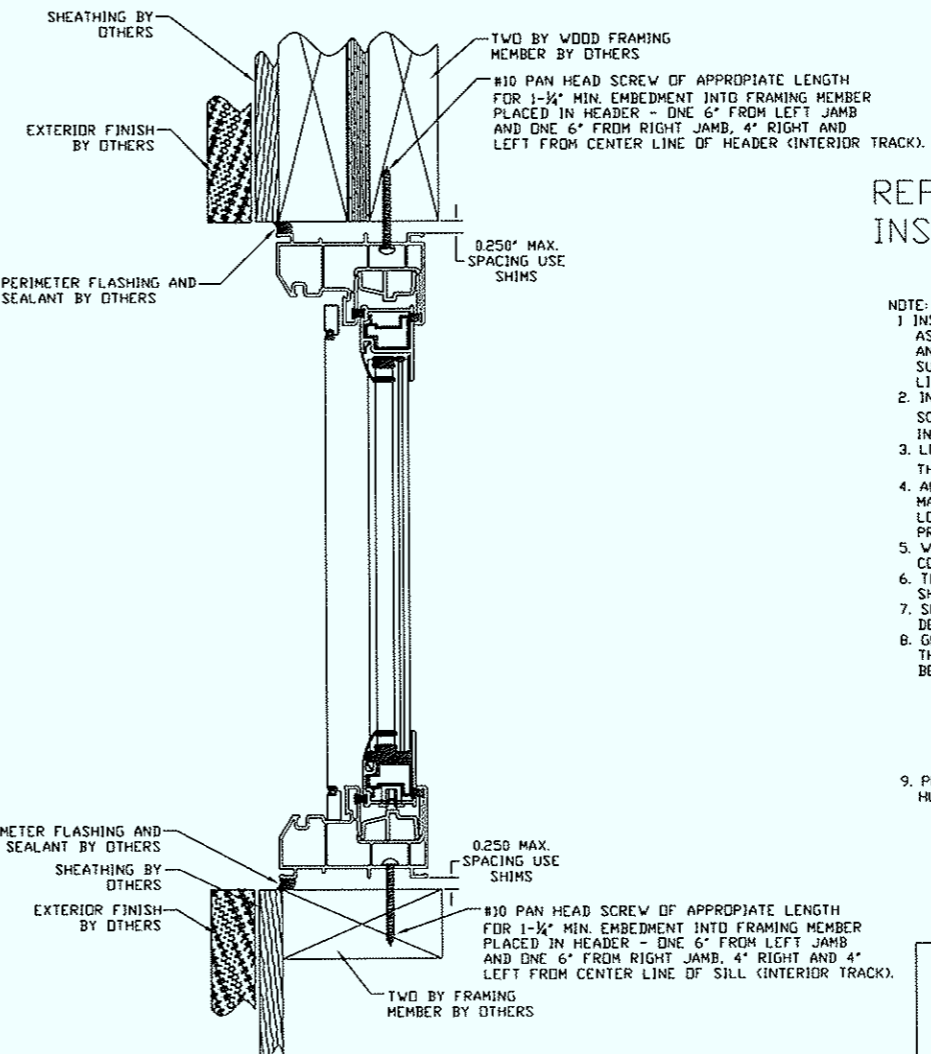

TABLE 1 - PRODUCT RATING	
MISSILE LEVEL	D
WIND ZONE:	3
DESIGN PRESSURE +/-	50
SIZE (width x height)	74 X 54
CAR (Certification Authorization Report)	105 & 204



HORIZONTAL CROSS SECTION - WINDOW IN WALL



VERTICAL CROSS SECTION - WINDOW IN WALL

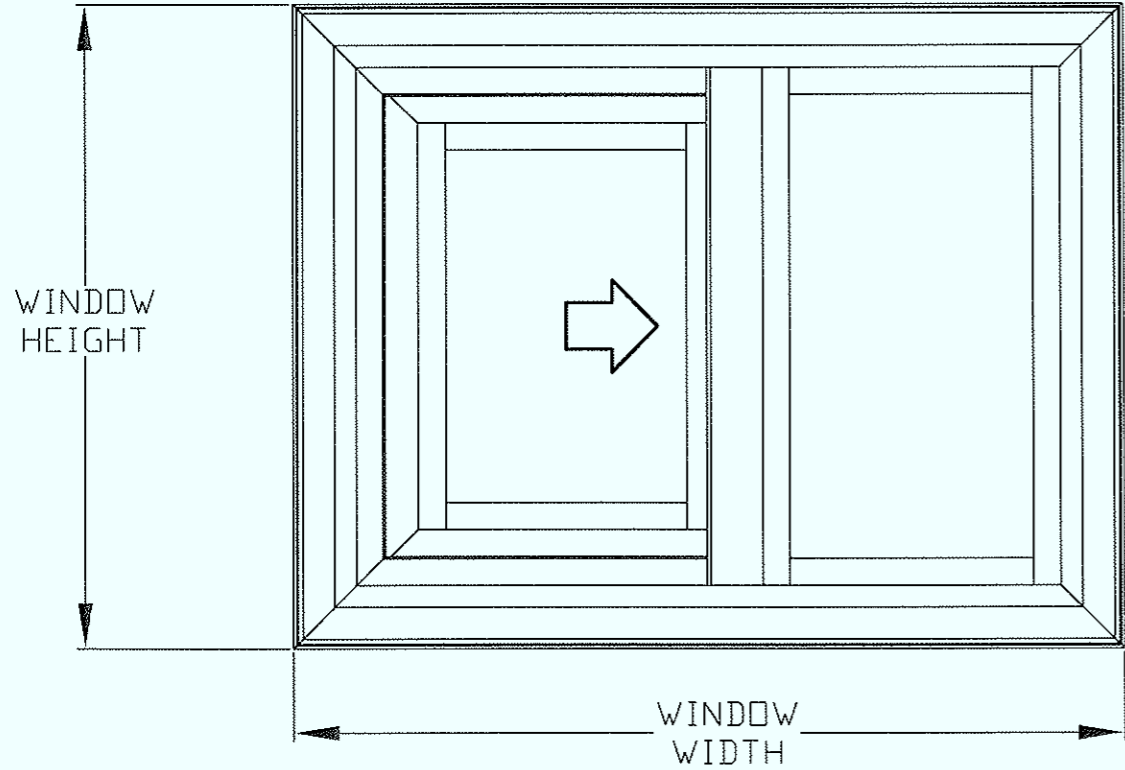

ELEVATION VIEWED FROM EXTERIOR SIDE

REPLACEMENT:
INSTALLATION INTO WOOD OPENING

- NOTE:
- INSTALLATIONS SHOWN ON THIS DRAWING HAVE BEEN VERIFIED AS THE AS-TESTED INSTALLATION FOR THE PERFORMANCE SHOWN. INSTALLATION ANCHOR CAPACITY HAS ALSO BEEN VERIFIED FOR THE ANCHOR SIZE, SUBSTRATE AND INSTALLED CONDITION. VERIFIED PRODUCT RATINGS ARE LISTED IN TABLE 1.
 - INSTALLATION ANCHORS USED THROUGH MAINFRAME SHALL BE #10 WOOD SCREWS OF SUFFICIENT LENGTH TO ACHIEVE MINIMUM EMBEDMENT OF 1-1/4" INTO 2X WOOD BUCK.
 - LOAD BEARING SHIMS REQUIRED AT EACH ANCHOR WHERE SPACE IS GREATER THAN 1/8". MAXIMUM ALLOWABLE SHIM STACK TO BE 1/4".
 - ALL WOOD SCREWS SHALL SATISFY NATIONAL DESIGN SPECIFICATION FOR MATERIAL PROPERTIES AND DIMENSIONS PER NDS-2005 11.1.4.7. FASTENER LOCATION MUST MAINTAIN AN EDGE DISTANCE THAT SHALL BE SUFFICIENT TO PREVENT SPLITTING.
 - WOOD FRAMING SHALL BE SPRUCE-PINE-FIR (G=0.42) OR DENSER IN GOOD CONDITION.
 - THESE INSTRUCTIONS ADDRESS STRUCTURAL REQUIREMENTS ONLY. WINDOWS SHALL BE INSTALLED PER ASTM E2112.
 - SMALLER WINDOWS OF THE SAME CONSTRUCTION AND EQUAL OR LESSER DESIGN PRESSURES ARE COVERED BY THIS DRAWING.
 - GLAZING TYPE, GLASS TYPE, AND GLASS THICKNESS ARE ESTABLISHED BY THE CERTIFICATION AND SHALL SATISFY ASTM E 1300. GLAZING TYPE SHOWN BELOW:
 1/8" ANNEALED LITE EXTERIOR
 0.340" LAMINATED LITE INTERIOR WITH 0.090" PVB
 AIR SPACE 1/16"
 UNIT THICKNESS 7/8"
 - PRODUCT OR INSTALLATION IS NOT APPROVED FOR HIGH VELOCITY HURRICANE ZONE (HVHZ)

THERMAL INDUSTRIES
 A SUBSIDIARY OF ATRIUM COMPANIES INC.
 3700 HANEY CT
 MURRYSVILLE PA 15668-1711
 UNAUTHORIZED DUPLICATION PROHIBITED

TITLE TYP. INSTALL - 50 SSL IN WOOD OPENING				
FILE	SCALE NTS			
DATE 4/21/08	DESIGNER	DRAFTER B.V.K.	APPROVER	
SERIES	MATERIAL PVC	SHEET 2 OF 2	REV 0	SIZE B

TABLE 1 - PRODUCT RATING	
MISSILE LEVEL	D
WIND ZONE:	3
DESIGN PRESSURE +/-	50
SIZE (width x height)	74 X 54
CAR (Certification Authorization Report)	105 & 204

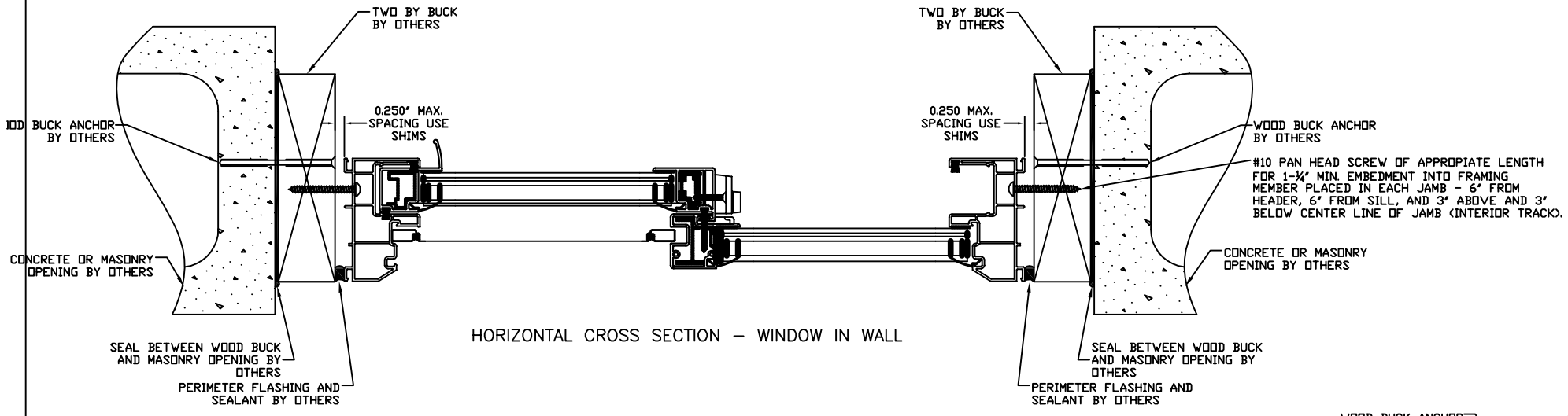

HORIZONTAL CROSS SECTION - WINDOW IN WALL

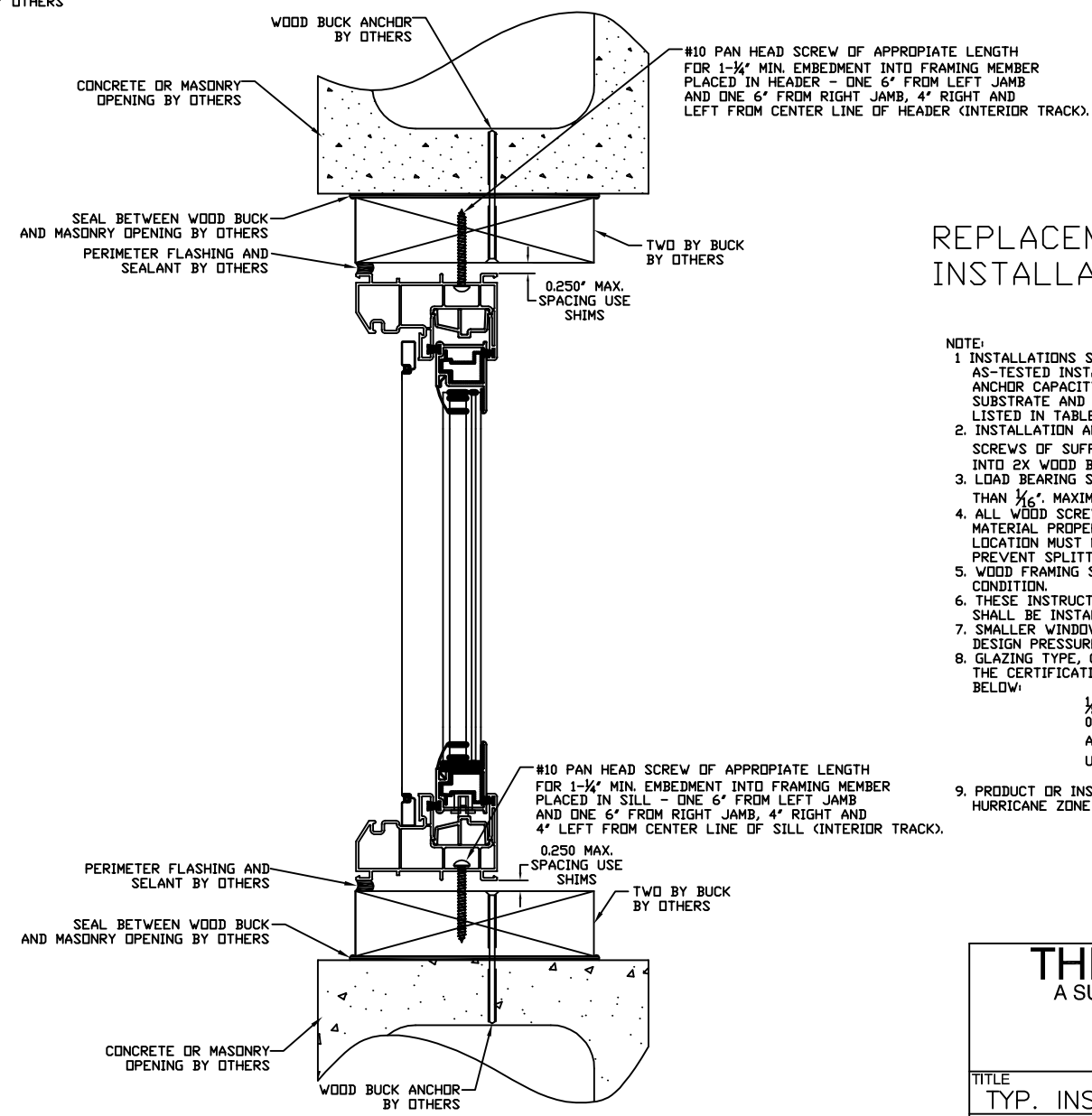

VERTICAL CROSS SECTION - WINDOW IN WALL

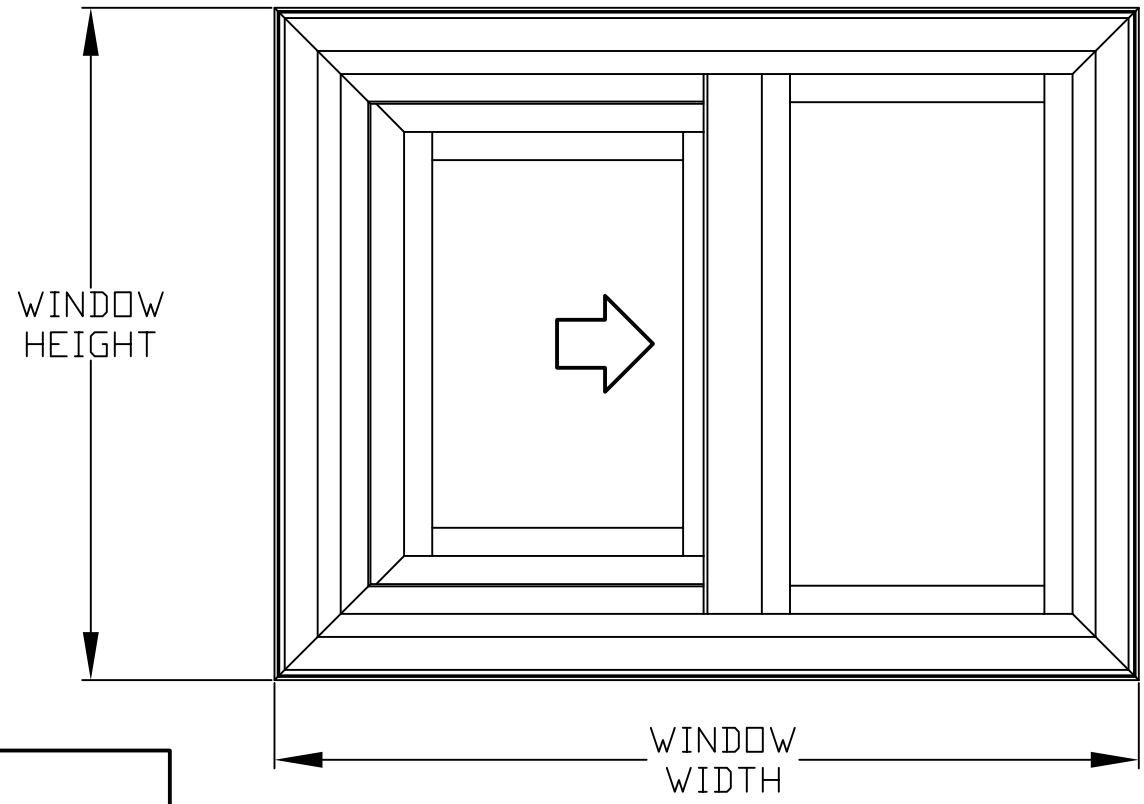

ELEVATION VIEWED FROM EXTERIOR SIDE

REPLACEMENT:
INSTALLATION INTO 2X BUCK

- NOTE:
1. INSTALLATIONS SHOWN ON THIS DRAWING HAVE BEEN VERIFIED AS THE AS-TESTED INSTALLATION FOR THE PERFORMANCE SHOWN. INSTALLATION ANCHOR CAPACITY HAS ALSO BEEN VERIFIED FOR THE ANCHOR SIZE, SUBSTRATE AND INSTALLED CONDITION. VERIFIED PRODUCT RATINGS ARE LISTED IN TABLE 1.
 2. INSTALLATION ANCHORS USED THROUGH MAINFRAME SHALL BE #10 WOOD SCREWS OF SUFFICIENT LENGTH TO ACHIEVE MINIMUM EMBEDMENT OF 1-1/4" INTO 2X WOOD BUCK.
 3. LOAD BEARING SHIMS REQUIRED AT EACH ANCHOR WHERE SPACE IS GREATER THAN 1/8". MAXIMUM ALLOWABLE SHIM STACK TO BE 1/4".
 4. ALL WOOD SCREWS SHALL SATISFY NATIONAL DESIGN SPECIFICATION FOR MATERIAL PROPERTIES AND DIMENSIONS PER NDS-2005 11.1.4.7. FASTENER LOCATION MUST MAINTAIN AN EDGE DISTANCE THAT SHALL BE SUFFICIENT TO PREVENT SPLITTING.
 5. WOOD FRAMING SHALL BE SPRUCE-PINE-FIR (G=0.42) OR DENSER IN GOOD CONDITION.
 6. THESE INSTRUCTIONS ADDRESS STRUCTURAL REQUIREMENTS ONLY. WINDOWS SHALL BE INSTALLED PER ASTM E2112.
 7. SMALLER WINDOWS OF THE SAME CONSTRUCTION AND EQUAL OR LESSER DESIGN PRESSURES ARE COVERED BY THIS DRAWING.
 8. GLAZING TYPE, GLASS TYPE, AND GLASS THICKNESS ARE ESTABLISHED BY THE CERTIFICATION AND SHALL SATISFY ASTM E 1300. GLAZING TYPE SHOWN BELOW:
 - 1/8" ANNEALED LITE EXTERIOR
 - 0.340" LAMINATED LITE INTERIOR WITH 0.090" PVB
 - AIR SPACE 1/16"
 - UNIT THICKNESS 7/8"
 9. PRODUCT OR INSTALLATION IS NOT APPROVED FOR HIGH VELOCITY HURRICANE ZONE (HVHZ).

THERMAL INDUSTRIES
A SUBSIDIARY OF ATRIUM COMPANIES INC.
3700 HANEY CT
MURRYSVILLE PA 15668-1711
UNAUTHORIZED DUPLICATION PROHIBITED

TITLE TYP. INSTALL - 50 SSL IN WOOD OPENING				
FILE	SCALE NTS			
DATE 4/21/08	DESIGNER	DRAFTER B.V.K.	APPROVER	
SERIES	MATERIAL PVC	SHEET 2 OF 2	REV 0	SIZE B

Joseph A. Reed, P.E.
FL PE 58920
130 Derry Ct.
York, PA 17406
717-764-7700
Project 82444.05-122-34

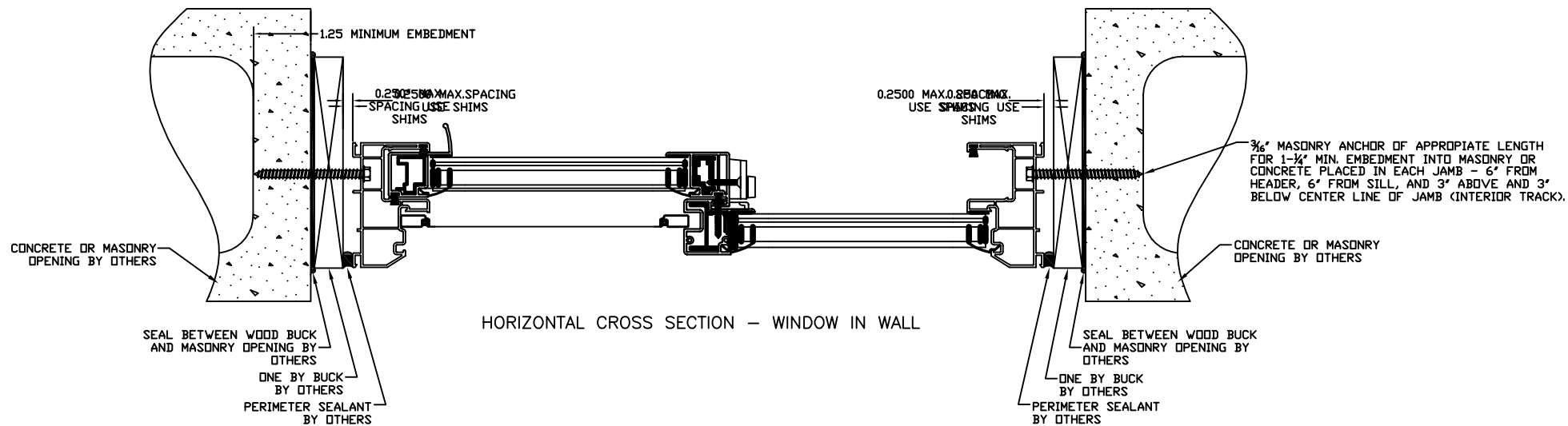

HORIZONTAL CROSS SECTION - WINDOW IN WALL

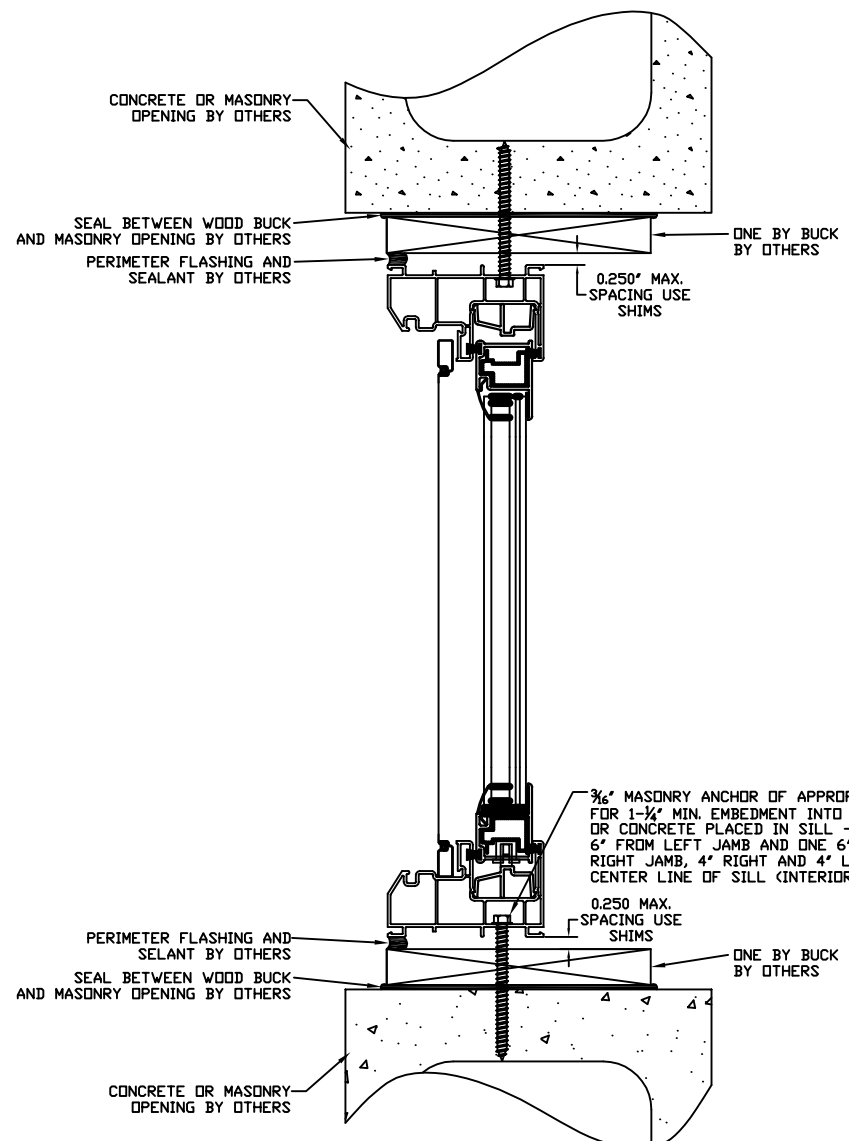

VERTICAL CROSS SECTION - WINDOW IN WALL

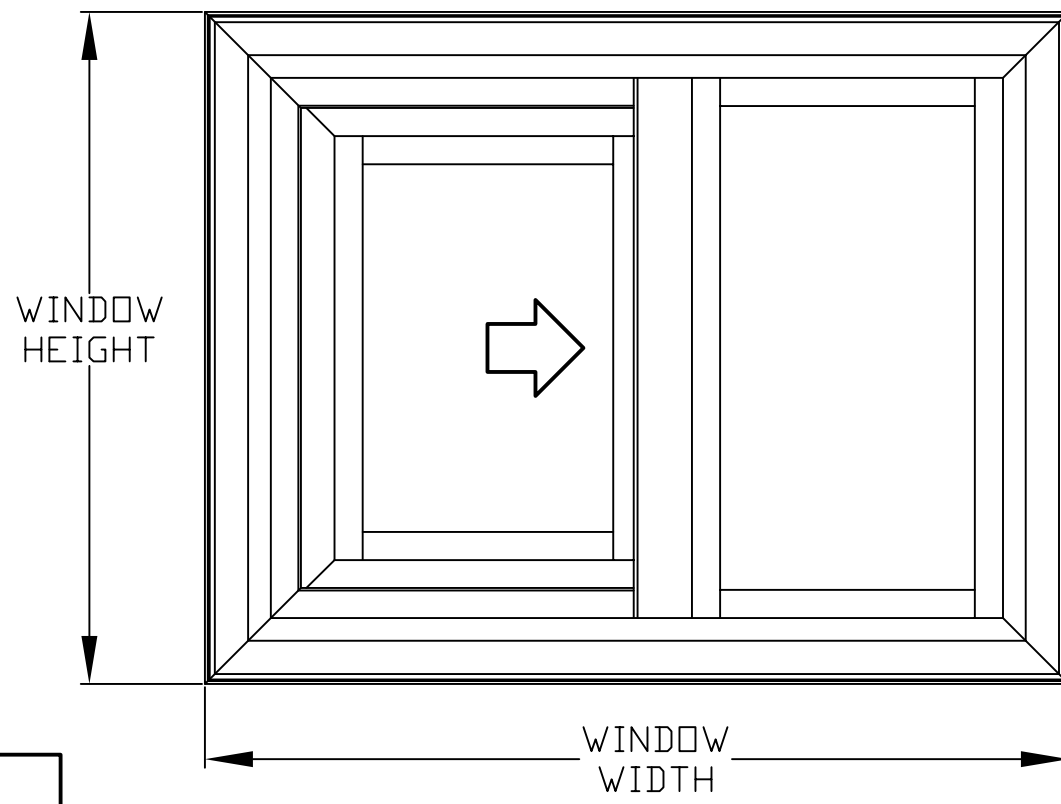

ELEVATION VIEWED FROM EXTERIOR SIDE

TABLE 1 - PRODUCT RATING	
MISSILE LEVEL	D
WIND ZONE:	3
DESIGN PRESSURE +/-	50
SIZE (width x height)	74 X 54
CAR (Certification Authorization Report)	105 & 204

REPLACEMENT:
INSTALLATION INTO 1X BUCK

- NOTE:
- INSTALLATIONS SHOWN ON THIS DRAWING HAVE BEEN VERIFIED AS THE AS-TESTED INSTALLATION FOR THE PERFORMANCE SHOWN. INSTALLATION ANCHOR CAPACITY HAS ALSO BEEN VERIFIED FOR THE ANCHOR SIZE, SUBSTRATE AND INSTALLED CONDITION. VERIFIED PRODUCT RATINGS ARE LISTED IN TABLE 1.
 - INSTALLATION ANCHORS USED THROUGH MAINFRAME SHALL BE 3/8" CONCRETE ANCHORS WITH HEX WASHER HEAD OF SUFFICIENT LENGTH TO ACHIEVE MINIMUM EMBEDMENT OF 1-1/4" INTO CONCRETE OR MASONRY BLOCK.
 - CONCRETE ANCHORS SHALL BE 3/8" TAPCONS CONFORMING TO IC ESR-1671 OR EQUAL VALENT. REFER TO ESR REPORT FOR INSTALLATION PROCEDURE OF ANCHORS.
 - ALL CONCRETE ANCHORS SHALL HAVE MINIMUM TENSION VALUE OF 60 POUNDS AND MINIMUM SHEAR VALUE OF 130 POUNDS.
 - LOAD BEARING SHIMS REQUIRED AT EACH ANCHOR WHERE SPACE IS GREATER THAN 1/8". MAXIMUM ALLOWABLE SHIM STACK TO BE 1/4".
 - 1X WOOD FRAMING BUCK SHALL BE SPRUCE-PINE-FIR (G=0.42) OR DENSER IN GOOD CONDITION.
 - THESE INSTRUCTIONS ADDRESS STRUCTURAL REQUIREMENTS ONLY. WINDOWS SHALL BE INSTALLED PER ASTM E2112.
 - SMALLER WINDOWS OF THE SAME CONSTRUCTION AND EQUAL OR LESSER DESIGN PRESSURES ARE COVERED BY THIS DRAWING.
 - GLAZING TYPE, GLASS TYPE, AND GLASS THICKNESS ARE ESTABLISHED BY THE CERTIFICATION AND SHALL SATISFY ASTM E 1300. GLAZING TYPE SHOWN BELOW:

1/8" ANNEALED LITE EXTERIOR
0.340" LAMINATED LITE INTERIOR WITH 0.090" PVB
AIR SPACE 7/16"
UNIT THICKNESS 7/8"

- PRODUCT OR INSTALLATION IS NOT APPROVED FOR HIGH VELOCITY HURRICANE ZONE (HVHZ)

Joseph A. Reed, P.E.
FL PE 58980
130 Derry Ct.
York, PA 17406
717-764-7700
Project 82444.05-122-34

THERMAL INDUSTRIES
A SUBSIDIARY OF ATRIUM COMPANIES INC.
3700 HANEY CT
MURRYSVILLE PA 15668-1711
UNAUTHORIZED DUPLICATION PROHIBITED

TITLE TYP. INSTALL - 50 SSL IN WOOD OPENING				
FILE	SCALE NTS			
DATE 4/21/08	DESIGNER	DRAFTER B.V.K.	APPROVER	
SERIES	MATERIAL PVC	SHEET 2 OF 2	REV 0	SIZE B